

Like any other industrial valve steam traps are subject to wear and their correct functioning can be impaired by precipitated solids and dirt deposits.

To assess the performance of a steam trap the following questions have to be answered:

- Does the steam trap work properly?
- If not, does the faulty trap cause a loss of steam (leakage) or banking-up of condensate (obstructed discharge passage)?

Faulty steam traps are a major source of waste in a steam distribution system. A trap that is blowing live steam is the worst offender, but traps that are plugged or stuck closed can also be costly.

The decreased plant efficiency due to loss of energy and additional make-up water results in lost production. Furthermore, an increase of pressure is liable to arise in condensate systems which will lead to difficulties at all locations where condensate is discharged.

The magnitude of such a steam loss depends on the cross-sectional area of the leak and, at the same time, the amount of discharged condensate. Locations where only small amounts of condensate are formed and discharged, e. g. drainage points in steam lines and tracing systems, are particularly problematical. On the other hand, locations where relatively large amounts of condensate are discharged will not give rise to considerable loss of live steam because of the presence of a large volume of liquid.

Steam traps which are **obstructed or stuck closed** do not cause loss of energy and/or water but reduce – to a greater or lesser extent – the efficiency of heat-transfer equipment and steam users. And waterhammer caused by condensate banking-up leads to considerable physical damage in steam and condensate systems.

Experience shows that installations where no regular trap testing and servicing takes place have a failure rate of defective steam traps in the order of 15 – 25 %. Regular maintenance and trap testing, which should be carried out at least once a year, can strongly reduce the failure rate to 5 %.

Test Systems

Steam traps can be tested during operation by using **sightglasses**, **ultrasonic listening devices** or **level meters**.

Sightglasses (Vaposcopes Type VK 14, VK 16) provide an effective means of observing the flow of liquids in pipework. They are installed upstream of the traps, and allow the assessment of the traps by making their operation visible. A satisfactory trap installation must pass all the water that flows to it without discharging live steam and must not be rendered inoperative by particles of dirt or by an accumulation of air.

Level meters use conductivity to monitor steam trap performance. A test chamber with an integral level electrode is installed upstream of the trap to detect any defective steam trap. The corresponding output signal is displayed by the **Remote Test Unit NRA 1-3x** (remote monitoring).

The system **VKE** can monitor all types and makes of steam traps to detect loss of live steam. The correct operation of RHOMBUS/line steam traps type BK 45/46, MK 45, UBK 46 can be verified by using the compact-type level probes NRG 16-19, NRG 16-27 and NRG 16-28. The test station NRA 1-3x will evaluate the data coming from the system VKE.

Another way to test traps is to use an **ultrasonic listening device** which detects the sound produced by steam flowing through the traps. Depending on the test system used the sound sensed by the device is either graphically represented in the form of a curve (**VKP 40**) or indicated by the deflection on the scale of a meter (**VKP 10**). When using the VKP 10, the field data specialist has to assess the indicator deflection and, consequently, the operation of the steam trap. The VKP 40, however, can directly track leaks associated with faulty steam traps and provides comprehensive reporting and a complete trap survey history.

Annual costs caused by steam loss

| | | |
|--|---|---|
| Number of steam traps installed | | <input type="text"/> |
| Annual failure rate (Empirical value with first check approx. 15 – 25 %) | | <input type="text"/> |
| A | Number of defective steam traps | <input type="text"/> |
| B | Steam loss per steam trap (kg/h) | <input type="text"/> |
| C | Annual operating hours | <input type="text"/> |
| D | Annual steam loss (kg) | <input type="text"/> A x B x C = <input type="text"/> |
| E | Cost of steam per ton | <input type="text"/> |
| F | Annual loss in EURO | <input type="text"/> D / 1000 x E = <input type="text"/> |

Example

| | | |
|----------|--|------------------|
| A | Number of defective steam traps | 10 |
| B | Steam loss per steam trap | 3 kg/h |
| C | Annual operating hours | 8000 h |
| D | Annual steam loss | 240000 kg |
| E | Cost of steam per ton | 30 Euro/t |
| F | Annual loss | 7200 Euro |

By the way:
A new steam trap costs – depending on the end connection – only approx. € 160 to € 200.

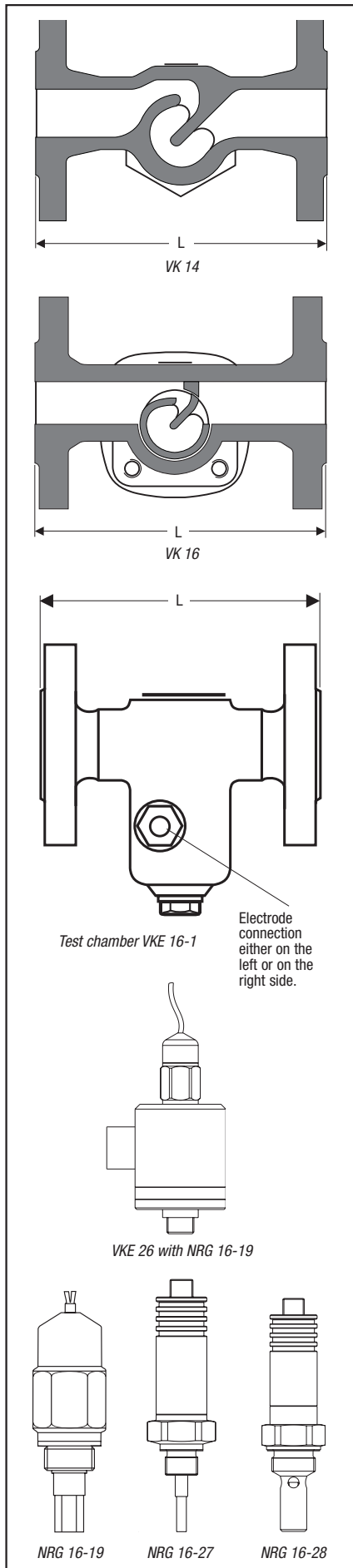

Application

| | |
|-------------------------------------|--|
| Type | |
| Vaposcope VK 14, VK 16 | Sightglass mit Borosilikatglas for checking heat exchangers and steam traps (installation up-stream of the traps). Visual supervision of flow conditions in condensate lines. |
| VKE | Test chamber with level electrode for monitoring steam traps to detect loss of live steam/banking-up of condensate. Installation in horizontal lines. |
| Vapophone VKP 10 | Ultrasonic detector for detecting steam leakage in steam systems; for monitoring steam traps and stop valves. |
| TRAPtest VKP 40/VKP 40Ex | Computer-based monitoring, recording and evaluation system for steam traps of all types and makes to detect loss of steam and condensate banking up. |
| NRG 16-19 NRG 16-27 NRG 16-28 | Level electrodes for installation in the test chamber VKE or in the body of Rhombusline steam traps. Designed for detecting loss of live steam/banking-up of condensate (used in conjunction with test unit NRA 1.3). Response sensitivity 1.0 µS/cm. |

Vaposcope VK

The Vaposcope can be used in horizontal and vertical pipework without any modifications.

Installation upstream of the steam trap.

The application is limited to fluids with pH value 9 (VK 14) or 10 (VK 16).

VK 16 comes standard with mica disc.

Test Set VKE

Consisting of: **Test chamber with integral level electrode NRG 16-19 / NRG 16-27** for steam traps of all types and makes. And: **Test Unit NRA 1.3** for continuous remote monitoring of up to 16 steam traps at the same time for loss of live steam or banking-up of condensate.

Pressure/Temperature Ratings *)

| Type | PN | Material | | Max. Pressure/Temperature Rating | |
|-------------------------------------|----|-------------------------|---------------------------|----------------------------------|---------------------------------|
| | | EN | ASTM | PMA / TMA | PMA / TMA |
| VK 14 | 16 | EN-JL 1040 | A 126 B ¹⁾ | 16 bar / 120 °C | 9.6 bar / 280 °C |
| VK 16 | 40 | P 250 GH | A 105 ¹⁾ | 40 bar / 20 °C | 25.8 bar / 300 °C |
| VKE 16-1 | 40 | GP 240 GH ²⁾ | A 216 - WCB ¹⁾ | 28.4 bar / 250 °C ³⁾ | 23.1 bar / 400 °C ³⁾ |
| VKE 16A STAINLESS STEEL | 40 | 1.4571 | TP 316 Ti ¹⁾ | 38 bar / 120 °C ³⁾ | 32.5 bar / 250 °C ³⁾ |
| VKE 26 | 40 | P 250 GH | A 105 ¹⁾ | 40 bar / 20 °C | 25.8 bar / 300 °C |
| NRG 16-19 NRG 16-27 NRG 16-28 | 40 | 1.4404 | F 316L | 40 bar / 20 °C | 32 bar / 238 °C |

- 1) ASTM nearest equivalent grade is stated for guidance only. Physical and chemical properties comply with EN grade.
 - 2) Forged steel flange P 250 GH (1.0460).
 - 3) Max. working pressure/temperature of the electrodes: 32 bar / 238 °C. Sensitivity of electrodes NRG 16-19, NRG 16-27: 1.0 µS/cm.
- *) For more information see data sheet.

Available Connections and Overall Lengths

| Type | Connection | Overall length L in mm | | | | |
|------------------------|--|--|---------------|-------------|-----------------|-------------|
| | | DN 15 1/2" | DN 20 3/4" | DN 25 1" | DN 40 1 1/2" | DN 50 2" |
| VK 14 | Flanged EN PN 16 | 130 | 150 | 160 | 200 | 230 |
| VK 16 | Flanged EN PN 40 | 150 | 150 | 160 | 230 | 230 |
| | Flanged ASME 150 | 150 | 150 | 160 | 230 | 230 |
| | Flanged ASME 300 | 150 | 150 | 160 | 230 | 230 |
| | Screwed sockets | 95 | 95 | 95 | 130 | 210 |
| | Socket-weld | 95 | 95 | 95 | 130 | 210 |
| VKE 16-1 | Flanged EN PN 40 | 150 | 150 | 160 | - | - |
| | Flanged ASME 150 | 150 | 150 | 160 | - | - |
| | Flanged ASME 300 | 150 | 150 | 160 | - | - |
| | Screwed sockets | 95 | 95 | 95 | - | - |
| | Socket-weld | 95 | 95 | 95 | - | - |
| VKE 16 A | Flanged EN PN 40 | 160 | 160 | 160 | 200 | 230 |
| VKE 26 | External/internal thread 3/8" BSP | | | | | |
| NRG 16-19 NRG 16-27 | External thread 3/8" BSP | Nominal length = 31 mm with integrated Pt 1000 thermocouple | | | | |
| NRG 16-28 | External thread M 24 x 1.5 for installation in the bodies of the Rhombusline steam traps series with integrated Pt 1000 thermocouple | | | | | |

System VKE

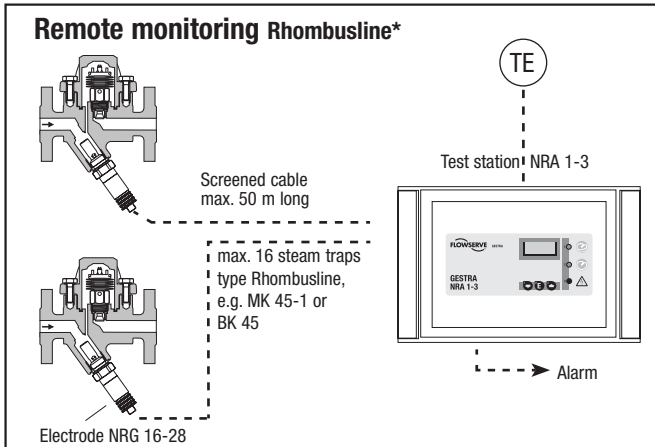

* Combination possible

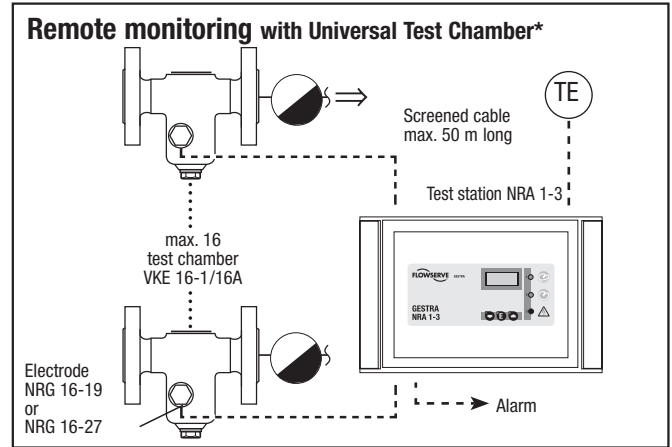

Vapophone VKP 10

The VKP 10 is used to detect sound in the ultrasonic range as caused by flowing steam through a steam trap.

The ultrasonic vibrations are detected by a probe and converted into electric signals which are indicated on the meter of a measuring instrument.

Protection: IP 41

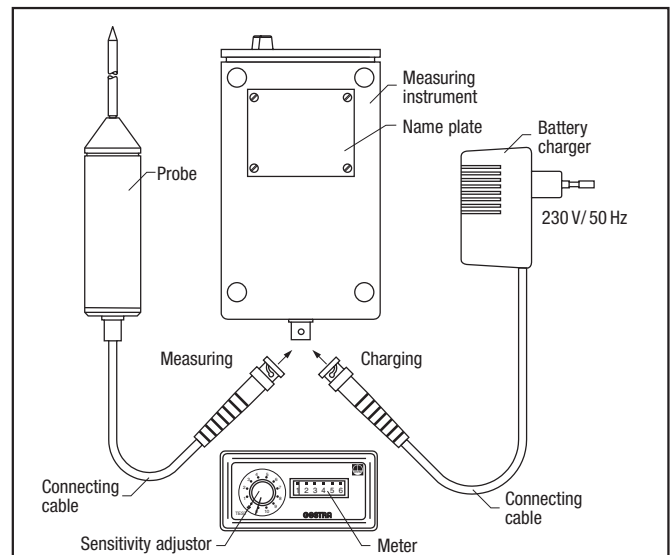

TRAPtest VKP 40/VKP 40Ex

Monitoring, Recording and Evaluation System for steam traps of all types and makes

With the aid of the VKP 40Ex (explosion proof) – intrinsically safe version for hazardous locations – or the VKP 40 steam traps can be checked for loss of live steam and banking-up of condensate, thus evaluating their performance. The PC software enables:

- Recording and organising of all steam trap data
- Storage and evaluation of all test results
- Simple and easy steam loss calculation for failed steam traps
- Print out of clearly listed repair jobs.

Features:

- Hand-held terminal with user-friendly interface for ease of operation (only 5 keys)
- Illuminated display for showing the recorded sound emissions as curves (visual indication of steam losses)
- Data exchange between PC and hand-held terminal at the click of the mouse
- PC software works with windows versions from other countries
- Protection: IP 65
- VKP 40Ex approval BVS 03 ATEX E 149

CE 0158 Ex II 2G Eex ib II C T4

